

PRODUCT SPECS

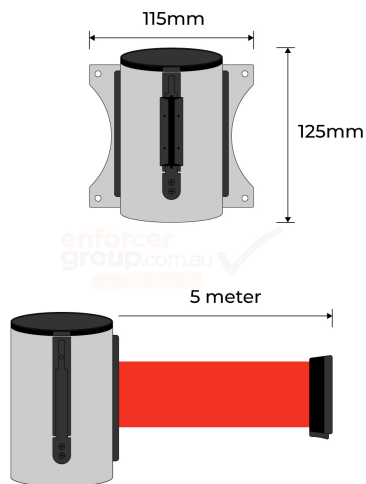

Product Code: WMB-SS-R

Height: 125mm

Width: 115mm

Weight: 0.5 kg

Strap Length: 5 metre

Fixings: Included

Finish: Stainless Steel with Red Nylon Strap



www.enforcergroup.com.au

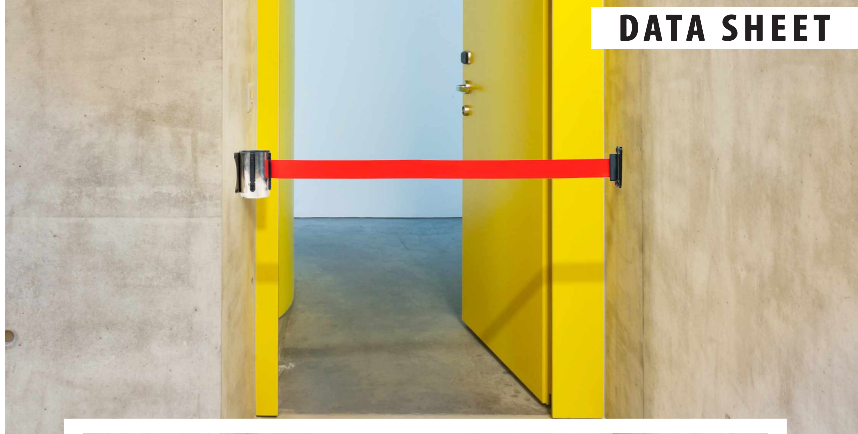

WALL MOUNT RETRACTABLE BARRIER STAINLESS STEEL WITH RED BELT

- Manufactured from Stainless Steel
- 5 metre Nylon Strap
- Easy to install

Enforcer Group's Wall Mount Retractable Barrier is a durable and sleek crowd control solution.

Made of stainless steel with a red nylon belt, it's perfect for managing queues in any setting.

Easy to install and use, it's stable and effective



Strong & Durable



Australian Standards Approved



Easy Installation

enforcer
group.com.au

Call us 1300 85 40 10

Address: 57-67 Popes Rd Keysborough Vic 3173 P.O. Box 3076 Ripponlea VIC 3185
Email: Sales@enforcergroup.com.au Phone: 1300 85 40 10