

PRODUCT SPECS

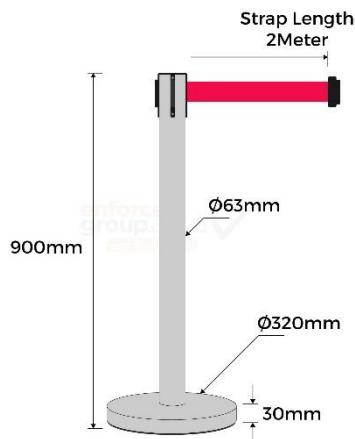

Product Code:	RB-SS-R
Diameter:	63mm
Height:	900mm
Weight:	6kg
Strap Length:	2 Meters (Red/Black)
Base Plate:	320mm diameter, 30mm height
Finish:	Polished Stainless Steel



1 Year
Manufacturing
Warranty



RETRACTABLE BELT BARRIER

- Silver polished stainless steel
- High quality 2meter nylon belt
- Durable Self-locking clips, features a 4-way connectivity
- Suited to use for crowd management in shopping centres, hotel, trade shows
- Easy to install, no fixings or tools required
- Available in red or black belt

Enforcer Retractable Belt Barrier Bollard are designed for Australian conditions, environmentally friendly manufactured from steel pipe, and 100% recyclable. Silver polished stainless steel, with a high quality 2meter nylon belt, durable Self-locking clips, features a 4-way connectivity. Easy to install or relocate, designed to be strong and durable, no fixings or tools are required, product comes with a base, post (includes the belt), and cover for the base. Suited to use for crowd management, guidance and direction, in shopping centres, hotels, trade shows, and all retail environments.



Strong &
Durable



Easy
Installation

enforcer
group.com.au

Call us 1300 85 40 10

www.enforcergroup.com.au

Address: 57-67 Popes Rd Keysborough Vic 3173 P.O. Box 3076 Ripponlea VIC 3185
Email: Sales@enforcergroup.com.au Phone: 1300 85 40 10