

# PRODUCT SPECS

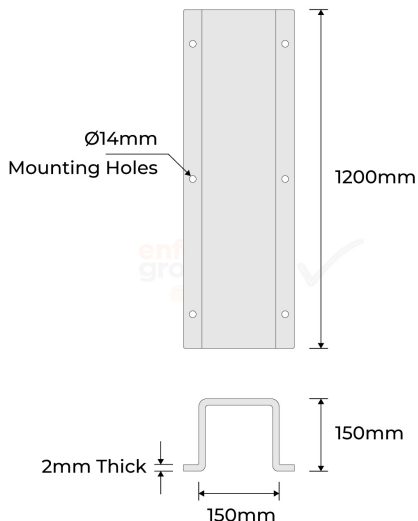

## DOWNPIPE PROTECTORS-150MM GALVANISED

Product Code:	DP-150-G
Width:	150x150mm
Height:	1200mm
Thickness:	2mm
Weight:	10kg
Mounting Holes:	14mm diameter
Finish:	Galvanised

- Manufactured from Galvanised Steel
- Withstand from heavy cars, trucks and forklifts
- Safety red & white finish
- Lightweight and easy to install
- Suitable for indoor and outdoor use

Enforcer Downpipe Protectors are your reliable defense against potential forklift and vehicle impact damage. Crafted to shield exposed PVC pipes, these high-strength guards are easily fitted to existing structures. Their design diverts impact away from pipes, cables, and large conduits, ensuring the safety of your assets.

Our Downpipe Protectors are standing guard, ready to deflect potential impacts and preserve the integrity of your infrastructure. Protect your assets with precision and strength.

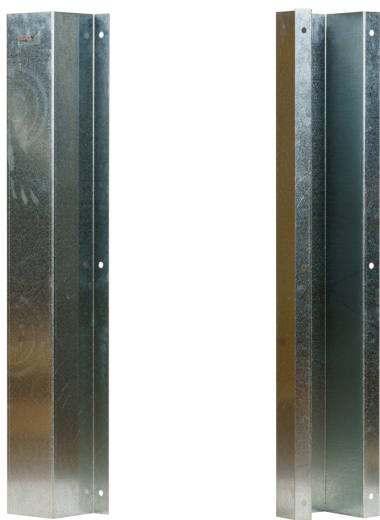

Strong & Durable



Australian Standards Approved



Easy Installation

**enforcer**  
group.com.au

Call us 1300 85 40 10